

# WIRE ROPE ISOLATORS: 'HELICAL'

DEFINITION  
**series C5H**

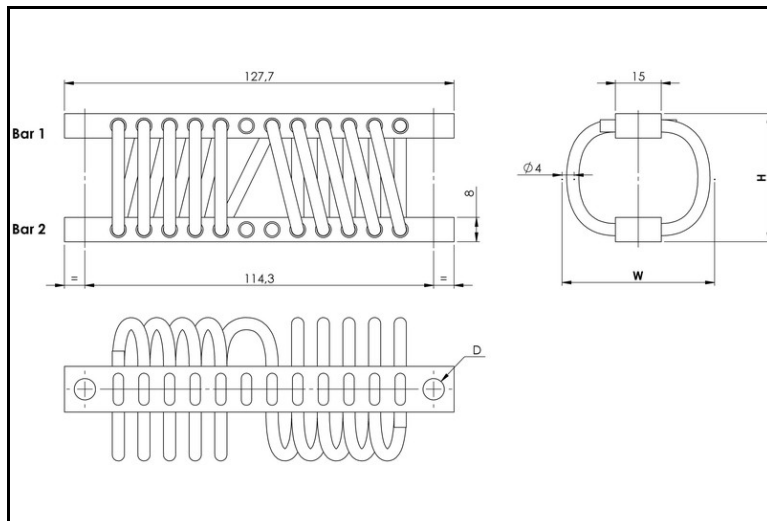

- All metal multidirectional anti-vibration/shock mounts
- Exceptional reliability and long life
- High damping
- No aging
- Corrosion resistant
- Unequalled temperature range : -180°C to +300°C / -290F to 570 F
- Great adaptability/versatility

### Specials on request

(material size and number of loops, etc.)

Dimensions are in millimeters. For reference only

SERIES
Materials and finishes (meets RoHS requirements)
<b>C5H</b>
<b>Cable:</b> stainless steel
<b>Retainer bars:</b> aluminium alloy/ SurTec
All stainless steel : C5HSS
Other materials on request

MODEL			
	height H (mm)	width W (mm)	weight (kg)
310	29	38	0,12
410	31	40	0,12
510	34	43	0,13
610	37	45	0,13
710	39	48	0,14
810	42	50	0,14
910	45	53	0,15
1010	52	62	0,16
1110	54	64	0,17
1210	54	72	0,17
1310	58	81	0,19

INTERFACES			
fixtures holes D	Bar 1		
	2 through holes Ø7mm	2 through holes Ø7mm countersunk k 90°	2 x M6
Bar 2			
2 through holes Ø7mm	no suffix	not standard	not standard
2 through holes Ø7mm countersunk 90°	CM	CM2	not standard
2 x M6	IM	CIM	IM2

**C 5 H 3 1 0 C I M**

SERIE: C5H

'Helical' mount from the C5H series

MODEL: 310

height: 29mm  
width: 38mm  
weight: 0,12kg  
loops: serie  
standard is 10 loops

INTERFACE: CIM

2 through holes Ø7mm  
countersunk 90° in bar 1,  
2 x M6 in bar 2



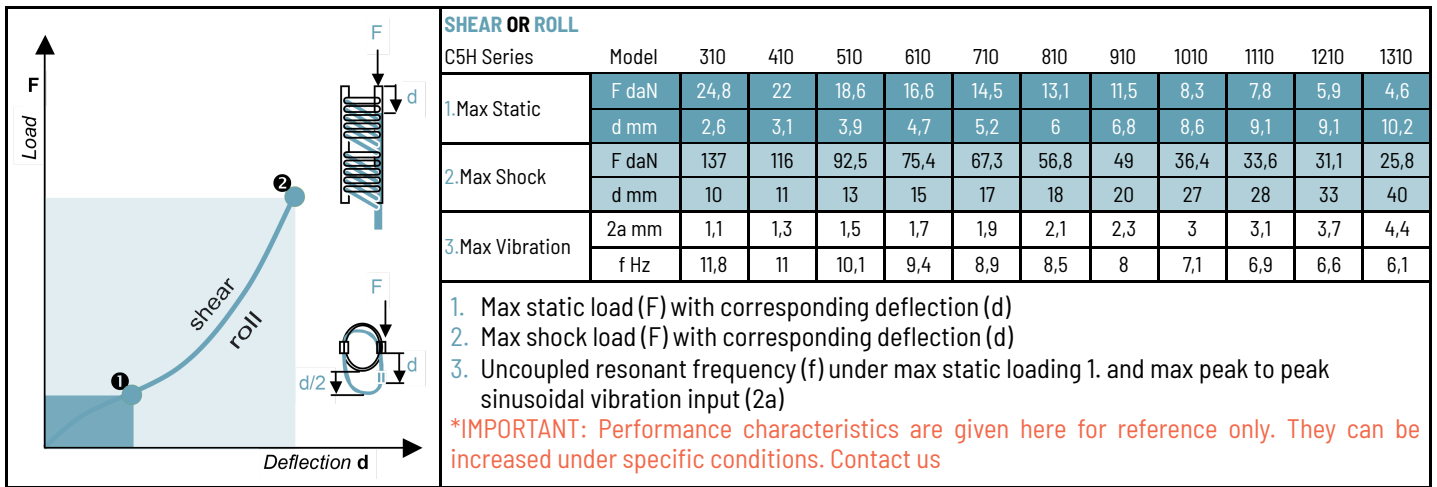
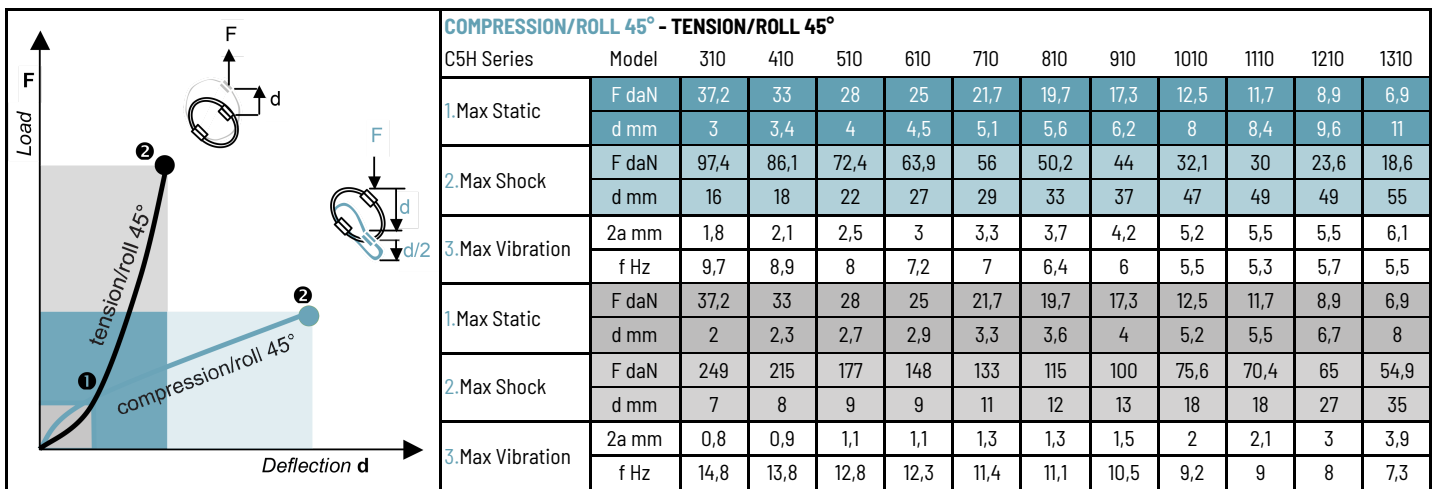
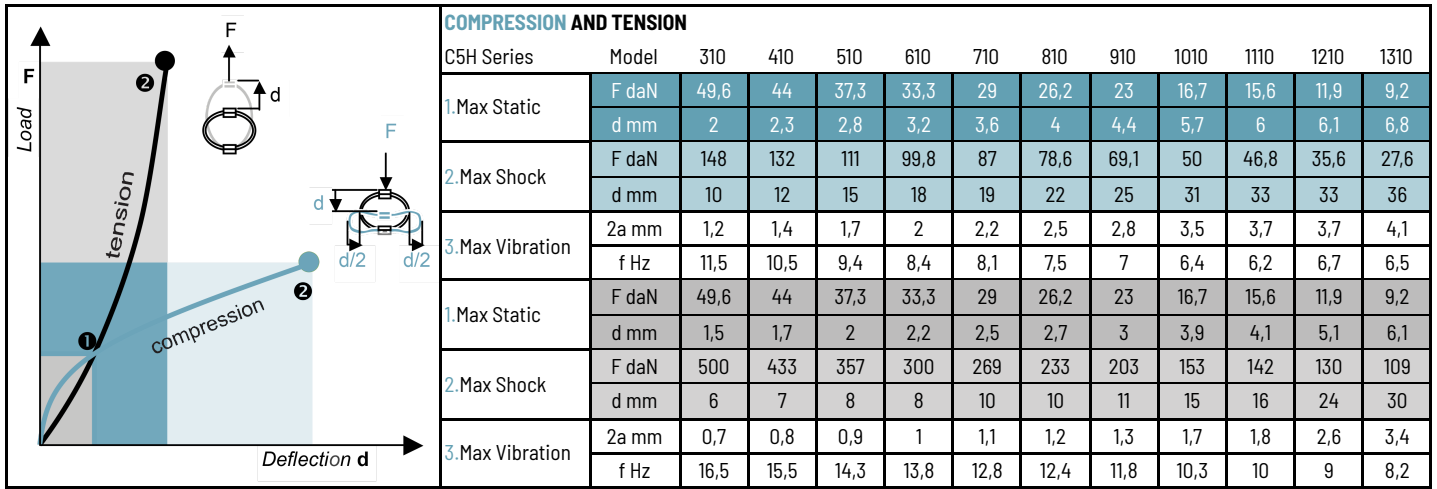

## TYPICAL SHOCK/VIBRATION SPECIFICATIONS:

- Air** AIR 7306, MIL-E-5400, MIL-C-172, MIL-STD-810
- Ground Forces** GAM EG13A, SEFT 001, MIL-STD-810, VG 9533
- Marine** GAM EG13C, IT25-21/96-31/15-86, MIL-S-167, MIL-S-901, STANAG 042, BV 043.73, BV 044
- Others** GAM EMB1, GAM EMBT4, DEF STAN 07-55, IEC 571, FINABEL 2C