

FP 10030/2 Fodplade

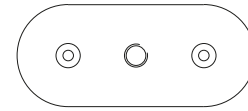

	Længde [mm]	Bredde [mm]	Tykkelse [mm]	Centerhul gevind
FP 10030/2	195	80	10	M16

## Produktbeskrivelse

Maskinsko MSL kan tage en stor belastning i forhold til størrelsen. MSL kan nemt anvendes til at få maskiner i vatter ved at dreje på gevindstangen, med en nøgle omkring SW.

## Anvendelse

Anvendes til en lang række applikationer som Produktionsmaskiner, Presser, Stansmaskiner, o.m.a.

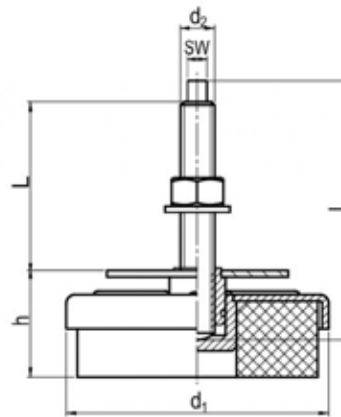

Type	d1 [mm]	d2 [mm]	h [mm]	l [mm]	L [mm]	Gevind SW
MSL-1	80	M12	38-48	100	75-65	8
MSL-2	120	M16	43-55	120	80-68	9
MSL-3	160	M20	48-63	170	125-110	12

Type	Statisk belastning [kg]	Maks. belastning ved > 200 slag / min [kg]	Maks. belastning ved 200 - 125 slag / min [kg]	Maks. belastning ved < 125 slag / min [kg]
MSL-1	600	120	140	200
MSL-2	1500	250	350	400
MSL-3	3000	700	1000	2500