

Product description

CMA mounts have a design similar to CMH and CML. The advantage of this mount is that the rubber compound provides high internal damping.

This special rubber compound means the mount provides good vibration and stability to equipment with high-amplitude vibrations.

Technical properties

- The upper part protects the rubber from fuel and oil.
- The metal parts are electro-galvanised.
- The CMA mount is a secured mount whose design prevents the separation of the two metal parts, even in case of high shock loads

Application

This mount is specially designed to isolate engines that produce high-amplitude vibrations.

Engines with 1-3 cylinders, motor-driven pumps, generators, compressors, fans, etc.

These mounts are suitable for engines and machines that start and stop frequently. When it starts and stops the engine goes through the resonant frequency, amplifying the vibrations, which is why the CMA mount is made with a rubber compound with high internal damping. The CMA mount is also good under machines which have rpms near the system's resonance frequency.

CMA mounts can advantageously be used for diesel engines with few cylinders, especially when the cylinder diameter is large and has a short stroke length. This often means that the engine generates high amplitude oscillations, and thus requires additional attenuation to stabilise.

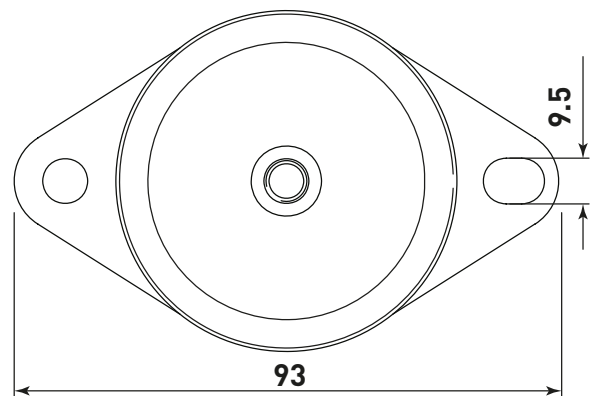
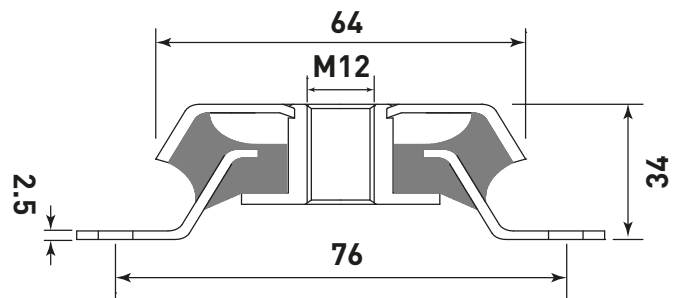

Type	Dimensions		Maximum load [kg]	Deflection [mm]
	B [mm]	H [mm]		
CMA-0	93	34	130	3.5
CMA-2	93	34	110	3.5
CMA-3	93	34	70	3.5

